

SERIES 3016 – Technical specification

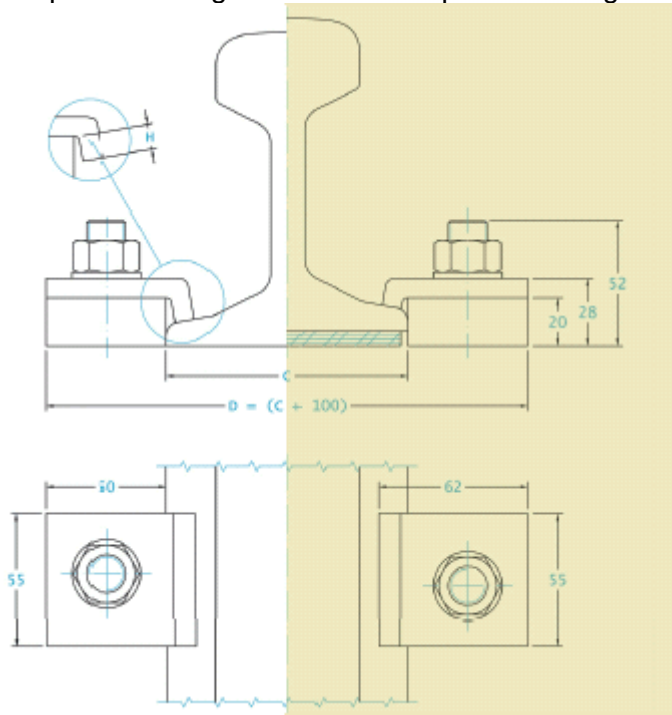

Without pad mounting

With pad mounting



Side load 50 KN

Torque tightening 175 Nm

Screw M 16 Quality 8.8

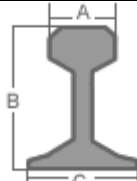
	A [mm]	B [mm]	C [mm]	Without Pad	With Pad
S33	58	134	105	3016-28-12	3016-28-5
36 UNI	60	130	100	3016-28-12	3016-28-5
46 UNI	65	145	135	3016-28-12	3016-28-5
50 UNI	67	148	135	3016-28-12	3016-28-5
S49	68	149	125	3016-28-12	3016-28-5
UIC 54	70	159	140	3016-28-9	-----
60 UNI	72	172	150	3016-28-9	-----
A45	45	55	125	3016-28-12	3016-28-5
A55	55	65	150	3016-28-12	3016-28-5
A65	65	75	175	3016-28-12	3016-28-5
A75	75	85	200	3016-28-9	-----
A100	100	95	200	3016-28-9	-----
A120	120	150	220	3016-28-5	-----
A150	150	150	220	3016-28-5	-----
CR105	65	131.7	131.7	3016-28-9	-----
CR135	87.3	146	131.7	3016-28-9	-----

DIMENSIONS [mm]	E	F	G	H	I	L	L1	L2	M	N	O	P	WEIGHT [Kg]
3016-28-5	-	-	-	5	-	-	-	-	-	-	-	-	0.600
3016-28-9	-	-	-	9	-	-	-	-	-	-	-	-	0.600
3016-28-12	-	-	-	12	-	-	-	-	-	-	-	-	0.600